

**Project Submittal
for
Sustainability Committee
Loan Funding:**

**Illini Union Bookstore
HVAC Retrocommissioning**

Date: 4/1/10

Prepared by: David C. Guth

APPLICATION INFORMATION

Project Lead Contact Information

Name: Jim Clark
E-mail: jclark76@illinois.edu
Phone: 333-3954

Address:
Illini Union, MC-384
1401 W. Green Street
Urbana, IL 61801

Title: Facilities Operations Manager
Organization/Department:
Illini Union/Facilities Maintenance &
Operations

Secondary Contact Information

Name: David Guth
E-mail: dcguth@illinois.edu
Phone: 244-1505
Title: Assistant to the Director
Organization/Department:
Illini Union/Facility Maintenance &
Operations

Address:
Illini Union, MC-384
1401 W. Green Street
Urbana, IL 61801

**Unit Financial Officer Contact
Information:**

Name: Scott McCartney
Phone: 333-3955
E-mail: smccart1@illinois.edu
Title: Assistant Director – Business Affairs
Organization/Department:
Illini Union/Business Affairs

Address:
Illini Union, MC-384
1401 W. Green Street
Urbana, IL 61801



Detailed Project Description

I. Project Goals

- **Primary Goals:**

1. **Increase HVAC efficiency by a conservative 15% within the Illini Union Bookstore.**
2. **Educate students** on the impact retrocommissioning has on energy conservation and the potential environmental and economic savings resulting from it. This will be accomplished through The Illini Union Marketing Department communicating the project progress and outcomes using “*Under GREENstruction*” signs outside of the spaces where the retrocommissioning is taking place. As well, Illini Union will also provide information regarding the project and the Sustainability Committee on our website and digital signage.

- **Defining Sustainability & Project Impacts**

1. **Definition:** Using the broad definition adopted by Student Affairs was stated in the 1987 report of the UN Commission on Environment and Development, the Illini Union targets projects providing trans-generational, long-term solutions which consider the global impacts of our daily operations. We fully recognize the connection and interdependence between biological, environmental and economic systems and the potential impacts between them.
2. **Impacts:** The project seeks to reduce the impact of energy consumption by HVAC on the environment by installing more efficient controls within the system. This will include remote monitoring, scheduling, sensing and logic controls, and variable air flow controls while providing a comfortable interior environment for Illini Union customers and staff. Consequently, the energy usage reduction translates into tangible economic cost and environmental impact savings. By communicating the results to stakeholders, a change in consciousness may occur, tying behavior to wider benefits to the university community and wider world.

- **Feasibility**

1. **Electrical Evaluation:** The F&S Retrocommissioning (RCx) team targeted the Illini Union Bookstore building as one of the top priorities on campus due to the relatively new HVAC equipment with control features already in place, as well as efficient double-pane glass and exterior insulation. F&S RCx engineers have developed a number of projects that would significantly impact sustainability. The project scope has been established as implementing the following priorities:
 - Create and develop the web pages for the bookstore air handling units on the basement, first, and second floors similar to the units on the third and fourth floors of the building.
 - Incorporate occupancy schedules for the Bookstore zones of the building, based on input from designated Union staff



- Review the existing controls on the (3) Bookstore air handling units and make sure the equipment is operating properly.
- Implement new energy saving control strategies as needed.
- Evaluate and install new CO₂ and humidity sensors, if needed.
- Spot check some thermostats and VAV box controls in the space to make sure the equipment is operating correctly.
- Implement Variable Frequency Drives (VFDs) on supply and return fan vanes, (6 VFDs needed for the air handling units in the building).

The above scope outlines the F&S RCx team's opinion of the suggested work priorities for the Illini Union Bookstore. The Union staff will have input on these items as work progresses and evolves. The scope priorities may change depending on what is discovered during the retro-commissioning process.

2. Illini Union HVAC Design Correction:

- An extensive engineering survey of four key HVAC issues impacting the Illini Union Bookstore space has been completed. The F&S RCx team recommends that these items be addressed in conjunction with the Bookstore Building RCx project. The main four components are:
 1. Overheating of the Lower Level occupied space (due to poor original HVAC design coordination between the 1st floor return & Lower Level air handler supply ducts).
 2. Building over-pressurization (already addressed - complete).
 3. Required controls adjustment at seasonal change-over.
 4. Excessive heat in the Lower Level mechanical room (to be addressed with modifications to access doors and exhaust fan).
- The project cost is estimated at a **not-to-exceed budget of \$37,800** with a modest **\$570 annual efficiency gain** for the LL air handler. Following discussion with Suhail Barot of the Student Sustainability Committee, we propose including this project as part of the overall RCx project given its complementary nature and direct connection to the main Retrocommissioning project.
- **Estimated Project Longevity/Results on Campus:** Industry standards indicate the average estimated HVAC system life is **15 – 20 years; however, with proper preventative maintenance, the life of HVAC systems can be extended to 40-50 years.** Given the Illini Union Bookstore Building is already 16 years old, it has approximately **four years** before a major overhaul of the building systems. However, it is F&S recommendation that we undergo the RCx process in the Illini Union Bookstore building:
 1. The RCx process identifies defective components within the HVAC systems, reconfiguring and controlling them to function more efficiently, decreasing wear



and tear and extending their service life by 20 years (as part of a regular preventative maintenance program).

2. There are immediate benefits to energy savings and cost.

II. Budget & Fundraising:

- **Detailed Budget:**

1. Construction cost estimates from F&S propose a **not-to-exceed budget of \$112,800** established for the Bookstore portion of the building:
 - This includes **\$75,000** for Retrocommissioning and **\$37,800** for the HVAC Design Correction.

- **Funding:**

1. The non-Auxiliary portion of the building (the third, fourth and fifth floors) is already fully funded by University Administration at **approximately \$85,000**. Because the building systems are shared according to a condominium agreement between the University and the Illini Union and split (54% Illini Union/46% Facilities & Services), the Union's portion must be funded for both sides of the project to move forward.
2. **The total energy consumed for the entire building is \$400,000** worth of electrical and steam utilities per year.
3. Because this portion of the building is considered an Auxiliary unit, RCx is not funded to provide services to the Bookstore portion of building mostly located on the basement, first, and second floors of the building.
4. Illini Union is requesting an interest free loan from the Sustainability Committee to cover the total cost of the project, **\$112,800**, including the Illini Union Bookstore HVAC Design Correction.
5. Illini Union does not have capital funding allocated in the current fiscal year and is thus relying on loan funding from the Sustainability Committee.

- **Return on Investment:**

1. **Conservative Straight-line Payback Analysis:**
\$75,000 Project Cost/\$31,340 Annual Electric and Steam Savings = 4 years*
2. **The resulting reduction in greenhouse gas emissions is estimated to be 193 Short Tons, or 386,000 lbs.***

** Estimated with a conservative 15% energy efficiency gain model.*

III. Timeline

- We propose to start performing this work by mid April of 2010. The project shall be completed on or before the start of Fall classes in August 2010. The proposed schedule is contingent upon the timely execution of the agreement between F&S and Illini Union.



IV. Energy, Environmental, Social and Economic Impact

A. Renewable Energy Projects – N/A

B. Energy Efficiency Projects

- The Illini Union has already done significant planning for the future in terms of infrastructure upgrades to reduce energy costs. **This project should save \$31,340 annually for the Bookstore portion of the building.** The project should reduce the following utility inputs as follows:
 - Annual kilowatt consumption is estimated to be reduced by **7%***
 - Annual steam consumption is estimated to be reduced by **12%***
 - Annual chilled water consumption is estimated to be reduced by **17%***
- Over the life of the project (conservatively 4 years), the Retrocommissioning for the Illini Union portion of the building should save **\$125,360**, broken out as follows:
 - **\$6,268, or 85,162 kWh of electricity**
 - **\$10,447, or 550 cu/ft steam**
 - **\$14,625, or 1,362 Gallons of chilled water**
- Significant energy inputs to execute and maintain the project are unknown at this time.

** Base data supplied by F&S; conservative estimates have been extrapolated from this data based on assumptions lowering the estimated energy efficiency gain for the project (15% vs. 25% projected by F&S)*

C. Environmental Impact/Social Impact/Economic Impact

• Environmental Impact

An estimated annual 386,000 lbs. of CO₂ emissions will be reduced (based on 1.672 CO₂ lb/kWH). Additionally, all efforts will be made to recycle old fixtures and equipment.

• Social Impact

Retrocommissioning the Bookstore building HVAC systems and marketing the results to throughout the University community, especially to students, will build awareness of how we can minimize the environmental impact of modern climate-controlled facilities through implementing energy reduction strategies demonstrating cost savings.

• Economic Impact

By saving money on energy costs, the Illini Union Bookstore will be able to allocate its funding more effectively for other purposes and continue to provide more benefit to the students and other customers using the Bookstore. Total annual energy efficiency gains resulting from the Retrocommissioning and HVAC Design Correction are expected to be conservatively around **15%**, or **\$31,340**. Additionally, remote monitoring of the building systems by Illini Union Engineering will allow staff to operate more efficiently and identify potential issues up front.

V. Outreach and Education

- The Illini Union promotes their green projects and the Student Sustainability Committee.
- Union Hundreds of students that pass through the Illini Bookstore daily will experience the sensors.
- Students will be able to better understand the importance of using HVAC systems efficiently.
- This affords an opportunity for students to learn about ways to conserve energy in their daily activities and lives.
- Additional education on the project savings and information marketing the Sustainability Committee on the ‘under construction’ signs outside of the rooms during construction.
- We will also provide information regarding the Sustainability Committee on our website to promote the Committee.
- Providing this information will allow the many students that pass through the Bookstore building and those visiting the Illini Union website to learn about the Sustainability Committee and its importance to our building and campus.

Illini Union Bookstore HVAC Retrocommissioning

HVAC Efficiency Gain Projections	10%	15%	20%	25%
Illini Union Condo Division (54%)				
Annual Electric/Steam Costs -Bookstore	\$216,000	\$216,000	\$216,000	\$216,000
Annual Electric/Steam Savings	\$21,463	\$31,340	\$41,026	\$50,570
Project Cost - Bookstore	\$75,000	\$75,000	\$75,000	\$75,000
Project Cost - Bookstore HVAC Design Correction	\$37,800	\$37,800	\$37,800	\$37,800
Annual Straight Payback	6	4	3	3
kWH Cost/Year Savings %	5%	7%	10%	12%
Chilled Water Cost/Year Savings %	11%	17%	22%	28%
Steam Cost/Year Savings %	8%	12%	16%	20%
FY09 Energy Consumption (MBTU)	12,523	12,523	12,523	12,523
Estimated Energy Consumption Savings (MBTU)	1,252	1,879	2,505	3,131
Estimated CO2 Emissions Reduction - Bookstore	129	193	257	321
F&S Condo Division (46%)				
Annual Electric/Steam Costs -F&S Bldg.	\$184,000	\$184,000	\$184,000	\$184,000
Annual Electric/Steam Savings - F&S Bldg.	\$19,772	\$29,658	\$39,544	\$49,430
Project Cost - F&S Bldg.	\$85,000	\$85,000	\$85,000	\$85,000
Annual Straight Payback - F&S Bldg.	4.30	2.87	2.15	1.72
kWH Cost/Year Savings %	5%	7%	10%	12%
Chilled Water Cost/Year Savings %	11%	17%	22%	28%
Steam Cost/Year Savings %	8%	12%	16%	20%
FY09 Energy Consumption (MBTU)	10,668	10,668	10,668	10,668
Estimated Energy Consumption Savings (MBTU)	1,067	1,600	2,134	2,667
Estimated CO2 Emissions Reduction - F&S Bldg.	109	164	219	274
Total Building				
Annual Electric/Steam Costs -Entire Bldg.	\$400,000	\$400,000	\$400,000	\$400,000
Annual Electric/Steam Savings - Entire Bldg.	\$40,000	\$60,000	\$80,000	\$100,000
Project Cost - Entire Building - Entire Bldg.	\$160,000	\$160,000	\$160,000	\$160,000
Annual Straight Payback - Entire Bldg.	4.00	2.67	2.00	1.60
kWH Cost/Year Savings %	5%	7%	10%	12%
Chilled Water Cost/Year Savings %	11%	17%	22%	28%
Steam Cost/Year Savings %	8%	12%	16%	20%
FY09 Energy Consumption (MBTU)	23,191	23,191	23,191	23,191
Estimated Energy Consumption Savings (MBTU)	2,319	3,479	4,638	5,798
Estimated CO2 Emissions Reduction - Entire Bldg.	238	357	476	595

Illini Union Bookstore HVAC Retrocommissioning

Illini Union Condo Division Annual Utility Cost Projections	10%	15%	20%	25%
Electricity Cost Savings	\$4,293	\$6,268	\$8,205	\$10,114
Chilled Water Cost Savings	\$10,016	\$14,625	\$19,145	\$23,599
Steam Cost Savings	\$7,154	\$10,447	\$13,675	\$16,857
Electricity Rate, FY09 (\$ per kWh)	\$0.074	\$0.074	\$0.074	\$0.074
Chilled Water Rate, FY09 (\$ per Gal.)	\$10.740	\$10.740	\$10.740	\$10.740
Steam Rate, FY09 (\$ per Cu. Ft. Steam)	\$18.980	\$18.980	\$18.980	\$18.980
Electricity Savings (kWh)	58,323	85,162	111,484	137,418
Chilled Water Cost Savings (Gal.)	933	1,362	1,783	2,197
Steam Cost Savings (Cu. Ft. Steam)	377	550	721	888

F&S Engineering Services

Professional Services Agreement

Illini Union Bookstore – Retro commissioning proposal

Date: March 18, 2010

Facilities and Services

Engineering Services / Retro commissioning
1501 S. Oak St., MC-800
Champaign, IL 61820

Contact: Karl Helmink (217.244.6426)

Using Agency: Illini Union
University of Illinois at Urbana
Champaign
1401 West Green Street
Urbana, IL 61801

Contact: Mulugeta Ferede, (217.333.0693)

WO No. (Step): TBD

Project Understanding:

1. Overview: Provide retro commissioning services (RCX) for the bookstore portion of the Illini Union Bookstore building. Because this portion of the building is considered an auxiliary unit, RCX is not funded to provide services to the bookstore portion of building mostly located on the basement, first, and second floors of the building. However we are funded to work on the third, fourth and fifth floors of the building. According to the FY09 utility consumption data, this building consumes approx. \$400,000 worth of electrical and steam utilities per year. Retro commissioned buildings tend to average energy reductions of over 25% in the 12-15 buildings that we have completed to date. If we assume this to be true in this building, this would yield \$100,000 worth of avoided utility costs per year. Depending on how the bookstore shares the utility costs in the building, it appears reasonable to assume that at least \$50,000 per year can be avoided in the bookstore area of this building.
2. Suggested priorities of work:
 - a. Create and develop the web pages for the bookstore air handling units on the basement, first, and second floors much like the units on the third and fourth floors of the building. A single Union staff person should be granted “read-only” access to the web graphics. Rob Fritz of F&S should be contacted regarding this item.
 - b. Incorporate occupancy schedules for the bookstore areas of the building. This will be done in concert with input from the designated Union staff.
 - c. Review the existing controls on the (3) bookstore air handling units and make sure the equipment is operating properly. Implement new energy saving control strategies as needed.
 - d. Evaluate and install new CO2 and humidity sensors, if needed.
 - e. Spot check some thermostats and VAV box controls in the space to make sure the equipment is operating correctly. We may need to access mechanical equipment which resides above the ceiling of the bookstore merchandise area. If proper coordination occurs, this could happen during the Summer period when the store traffic may be lower.
 - f. The inlet vanes on the supply and return fans are an energy intensive way of modulating the airflow of on the variable air volume systems. Variable frequency drives (VFDs) could be

F&S Engineering Services

Professional Services Agreement

Illini Union Bookstore – Retro commissioning proposal

implemented on this units. This item typically has a payback of 2 years or less. There are 6 VFDs needed for the air handling units in the building.

3. Budget: We would propose that a not to exceed budget of **\$75,000** be established for the bookstore portion of the building. Item 2 above designates our opinion of the suggested work priorities for the bookstore. The Union staff will have input on these items as our work progresses and evolves. The priorities may change a bit depending on what is discovered during the retro-commissioning process. Periodic meetings will be held to achieve coordination with the Union staff. It is probably unlikely that all of the work listed in item 2 will be accomplished. The Union staff can then decide to defer this work until a future point in time after some savings have accrued.
4. Schedule: We would propose to start performing this work by mid April of 2010. The project shall be completed on or before the start of Fall classes in August 2010. The Proposed schedule is contingent upon the timely execution of this Agreement. Project schedule will be adjusted according to the date this fully executed Agreement is returned to us or the issuance of a valid work order and step for retro commissioning, whichever comes first.

In recognition of this Agreement:

Signature

Printed Name

Title

Date

Signature

Printed Name

Title

Date

ILLINI UNION BOOKSTORE

HVAC Evaluation

January 20, 2010
(Revised February 8, 2010)

Prepared by:
Facilities & Services
Engineering Services

TABLE OF CONTENTS

	Page
I. Executive Summary.....	1
II. Discussion.....	2-8
a. Overheating of the lower level	2
b. Building over-pressurization	4
c. Required controls adjustment at seasonal change-over	5
d. Excessive heat in lower level mechanical room	6
e. Energy consumption summary – with economizer	7
f. Energy consumption summary – without economizer	8
III. Appendix A: Photos	A 1-2
a. Location photos	A 1
b. Area well photos	A 2
IV. Appendix B: Plans and Details	B 1-4
a. Lower level plan	B 1
b. Damper location detail	B 2
c. Exhaust fan location	B 3
d. Proposed relief air modifications	B 4
V. Appendix C: Product Data	C 1-2
a. Fan product data	C 1
b. Ruskin damper product data	C 2 a-d

Executive Summary

February 8, 2010

Illini Union Bookstore
Lower level HVAC Issues

EXECUTIVE SUMMARY

The following four (4) issues were investigated by Engineering Services at the Illini Union Bookstore:

- 1. Overheating of the Lower level occupant space**
- 2. Building Over-Pressurization**
- 3. Required controls adjustment at seasonal change-over**
- 4. Excessive heat in Lower level mechanical room**

The following are our recommendations to eliminate these four (4) issues:

1. Overheating of the Lower level occupant space

Install ductwork to enclose the relief air from the first level air handler, and direct it away from the lower level air handler's intake. The final configuration of this ductwork is to be determined. Provide sheet metal closures at gaps under man doors in area wells. See discussion which follows.

Estimated construction cost: \$30,000

2. Building Over-Pressurization

This problem has been resolved. See discussion which follows.

Estimated cost: None

3. Required controls adjustment at seasonal change-over

The adjustment of controls seasonally should not be required once the intake temperature problem is resolved. See discussion which follows.

Estimated cost: None

4. Excessive heat in Lower level mechanical room

Installation of a small exhaust fan and a new makeup air damper are recommended and described below.

Estimated construction cost: \$6,000

Discussion

DISCUSSION

1. Overheating of the Lower level:

Problem:

This problem first surfaced in 2006 or 2007. It was determined that the lower level air handler's outdoor air temperature at the intake was elevated. This was caused by entrainment of relief air from the first floor air handler.

During Engineering Services' investigation of this problem data logging devices were deployed in the occupant spaces, outdoor air intake of the lower level air handler and in the outdoor air intake of the first floor air handler. Data collected from the first floor outdoor air intake represented actual outdoor air temperature, unaffected by the operation of other air handlers.

The outdoor air temperature at the intake of the lower level air handler was 10-20 degrees higher than the actual outdoor air temperature. The control of the mixing dampers (outdoor air and return air), and the relief damper are based upon the actual outdoor air temperature rather than the temperature of the outdoor air at the air handler intake.

For example, if the outdoor air temperature were 55 degrees, the lower level and first floor units are in full economizer mode – using 100% outdoor air to provide cooling. However, the temperature at the outdoor air intake for the lower level unit may be 75 degrees. This requires mechanical cooling to deliver colder air. At full economizer conditions (55 deg. OA temperature) the outdoor air damper should be 100% open, but at 75 degrees, the damper should be at its minimum position.

The added heat at the intake of the lower level air handler seems to be due to the location of the relief louver for the first floor air handler. It is located in the below ground intake well just above the outdoor air intake of the lower level air handler. The sheet metal deflector that was installed to solve the problem has proven to be ineffective. Additionally, heat comes from the exhaust well adjacent to this intake well, which is connected by man doors. There is a 14" gap between the bottom of the doors and the top of the threshold. This gap allows heated building exhaust air to be pulled over to the outdoor air intake well that serves the lower level air handler.

Installing a dedicated outdoor air sensor at the air intake of the lower level air handler was considered as a possible solution. Giving the control system correct feedback regarding the actual outdoor air temperature entering the unit would allow the control system to have the correct information for operation of the mixing dampers and should result in a better controlled discharge air temperature. However, with higher temperatures at the lower level intake, the Lower Level unit would not be able to take advantage of its economizer cycle. The result would be that the unit on the lower level would call for mechanical cooling when none of the other air handlers are. The chiller could not be operated under these conditions, as there would not be enough cooling load present to keep the chiller operating. Even if it were possible to operate the chiller under

these conditions, the additional energy cost that would be incurred by operating the chiller during the winter months would be difficult to justify. For these reasons we concluded that this approach would not solve the Lower Level overheating problem.

Solution:

Install ductwork on the relief air discharge of the first floor air handling unit to separate it entirely from the outdoor air intake of the lower level air handling unit. This needs to be ducted up and away from the lower level air intake. This is the most definitive, most effective means of addressing the problem.

Sheet metal closures should be fabricated to close off the gap under the man doors in the area wells. This will keep exhaust air from the adjacent area well from infiltrating into the outdoor air well.

Impact upon Energy Usage:

Due to the elevated temperatures at the outdoor air intake for the Lower Level air handler, this unit is unable to take full advantage of its economizer cycle. As it is currently operated, the unit effectively has no economizer.

To demonstrate the impact of this condition on the building energy usage, we developed an energy model using Trane Trace 700 energy software. This model considers only the Lower Level air handler. With our model we compared the energy usage of the Lower Level air handler with economizer cycle versus the air handler with no economizer cycle in order to demonstrate the cost impact of not being able to operate the unit in economizer mode.

The model assumes that mechanical cooling is available year-round. By comparing the energy used for cooling with economizer versus without economizer, we can see the impact upon energy usage.

The Energy Consumption Summary reports for the model with economizer and without are attached at the end of this section of the report. This output indicates that operating the air handler without an economizer cycle results in a net increase of 25,957 kBtu/yr (Total Building Energy cooling subtotal) over an air handler with an active economizer. Based on an average energy cost of \$0.075/kWh, this results in an annual operating cost increase of approximately \$570/yr for this air handler when the economizer is not used.

The primary reason for making the indicated system modifications is to provide for the comfort of the Bookstore employees and patrons. The energy savings that can be realized by correcting the problem of overheating in the Lower Level provides additional incentive to proceed with this project.

2. Building Over-Pressurization:

Problem:

From our investigation of the history of this problem, it seems that there was a problem at the Bookstore at one time, but it does appear that this issue has been corrected. The problem originated because a damper actuator linkage had slipped off the relief damper on the air handler that serves the second floor. This resulted in the relief damper being closed, with no path to balance the pressure on the second floor. Outdoor air was being drawn in, but there was no way to exhaust that quantity of air to the outside. Since the pressurization of the first and second floors are connected via the open stairwell that connects the two floors, and since there are no doors to the outside on the second floor, this problem manifested itself by doors on the first floor that would not shut completely.

Each floor is equipped with static pressure sensors, and the control system will increase or decrease the speed of the return fan as required to maintain a positive pressure on a given floor. As long as there is no major malfunction (such as described above with the relief damper), and as long as the static pressure sensors themselves are operating correctly, the building should maintain a slightly positive pressurization. However, opening doors, exhaust fans coming on and off, variability in the amount of outdoor air being brought into the building, etc., will result in some degree of variance in building pressure. It is reasonable to expect that the building will vary between being a little positive to a little negative at any given point in time, unless there is an equipment or component failure. This variance in the system is to be expected, and I do not see anything to indicate that there is a major problem with building pressurization at the present time.

Solution:

We did not observe any evidence of building over-pressurization during our site investigations. As long as all of the dampers on the first and second floor air handlers are functioning properly, there should be no recurrence of this issue.

3. Required controls adjustment at seasonal change-over:

There is usually an adjustment required during heating season to prevent freeze-stat trips on the lower level air handler. In the winter, building automation IT engineers go into the control program (via online interface) and set the mixed air temperature set-point a little higher than it is set during the cooling season. This has the effect of reducing the outdoor air, which raises the mixed air temperature and prevents freeze-stat trips. Of course, this has to be changed back during the cooling season. If there are unseasonably warm days during the heating season, then the space would overheat during those days.

We expect that when we resolve the problem with the overheating of the outdoor air for the lower level unit, this problem with the freeze stat trips will go away, and adjustment of the discharge air temperature will no longer be necessary.

The adjustment of the discharge air temperature set-point is only required because there is such a wide difference between the outdoor air temperature, and the actual temperature at the outdoor air intake at the Lower level air handler. If the relief air from the first level air handler is ducted away from the lower level unit's intake, then the intake temperature at the lower level should be the same as the actual outdoor air temperature.

4. Excessive heat in lower level mechanical room:

Problem:

This mechanical room is very congested. Determining the location for a new exhaust fan that would not interfere with existing equipment access, components, or instrumentation was difficult. Therefore the size of the exhaust fan was critical. Data loggers were placed at the outdoor air intakes, in the mechanical room, in Room 019 and one in the large open area (Room 001). The data loggers were monitored over a period of 3 – 4 weeks in April of 2009. The resultant data was used to determine the required exhaust fan size (see Appendix C – Product Data). The amount of exhaust needed to achieve a 15° decrease in temperature in the mechanical room was calculated.

Solution:

Add an exhaust fan to the exhaust louver plenum on the east side of the mechanical room. Install outdoor air damper approximately 15 feet away in the blanked-off louver directly to the north of the existing steam generator. A local thermostat will command the exhaust fan on whenever the temperature in mechanical room rises above set-point. The damper will open to allow make-up air to enter the room whenever the exhaust fan runs.

ENERGY CONSUMPTION SUMMARY

By UNIVERSITY OF ILLINOIS

	Elect Cons. (kWh)	Water Cons. (1000 gals)	% of Total Building Energy	Total Building Energy (kBtu/yr)	Total Source Energy* (kBtu/yr)
Alternative 1					
Primary heating					
Primary heating	2,287		0.8 %	7,805	23,418
Other Htg Accessories	20	2	0.0 %	70	209
Heating Subtotal	2,307	2	0.8 %	7,875	23,627
Primary cooling					
Cooling Compressor	67,357		23.1 %	229,890	689,738
Tower/Cond Fans	8,457		2.9 %	28,864	86,601
Condenser Pump			0.0 %	0	0
Other Clg Accessories	833		0.3 %	2,843	8,530
Cooling Subtotal....	76,647		26.3 %	261,597	784,869
Auxiliary					
Supply Fans	101,059		34.7 %	344,914	1,034,844
Pumps	1,324		0.5 %	4,519	13,559
Stand-alone Base Utilities			0.0 %	0	0
Aux Subtotal....	102,383		35.1 %	349,433	1,048,403
Lighting					
Lighting	110,166		37.8 %	375,996	1,128,100
Receptacle					
Receptacles			0.0 %	0	0
Cogeneration					
Cogeneration			0.0 %	0	0
Totals					
Totals**	291,503	2	100.0 %	994,900	2,984,999

* Note: Resource Utilization factors are included in the Total Source Energy value.

** Note: This report can display a maximum of 7 utilities. If additional utilities are used, they will be included in the total.

ENERGY CONSUMPTION SUMMARY

By UNIVERSITY OF ILLINOIS

	Elect Cons. (kWh)	Water Cons. (1000 gals)	% of Total Building Energy	Total Building Energy (kBtu/yr)	Total Source Energy* (kBtu/yr)
Alternative 1					
Primary heating					
Primary heating	2,287		0.8 %	7,805	23,418
Other Htg Accessories	20	2	0.0 %	70	209
Heating Subtotal	2,307	2	0.8 %	7,875	23,627
Primary cooling					
Cooling Compressor	73,753		24.7 %	251,719	755,232
Tower/Cond Fans	9,439		3.2 %	32,216	96,657
Condenser Pump			0.0 %	0	0
Other Clg Accessories	1,061		0.4 %	3,620	10,861
Cooling Subtotal....	84,253		28.2 %	287,554	862,749
Auxiliary					
Supply Fans	101,059		33.8 %	344,914	1,034,844
Pumps	1,324		0.4 %	4,519	13,559
Stand-alone Base Utilities			0.0 %	0	0
Aux Subtotal....	102,383		34.2 %	349,433	1,048,403
Lighting					
Lighting	110,166		36.8 %	375,996	1,128,100
Receptacle					
Receptacles			0.0 %	0	0
Cogeneration					
Cogeneration			0.0 %	0	0
Totals	299,109	2	100.0 %	1,020,858	3,062,879

* Note: Resource Utilization factors are included in the Total Source Energy value.

** Note: This report can display a maximum of 7 utilities. If additional utilities are used, they will be included in the total.

Appendix A

Photos

Equipment Location photos
Area well photos

A 1
A 2



Photo 1: Steam generator close to blanked-off louver. See sketch in Appx. B.

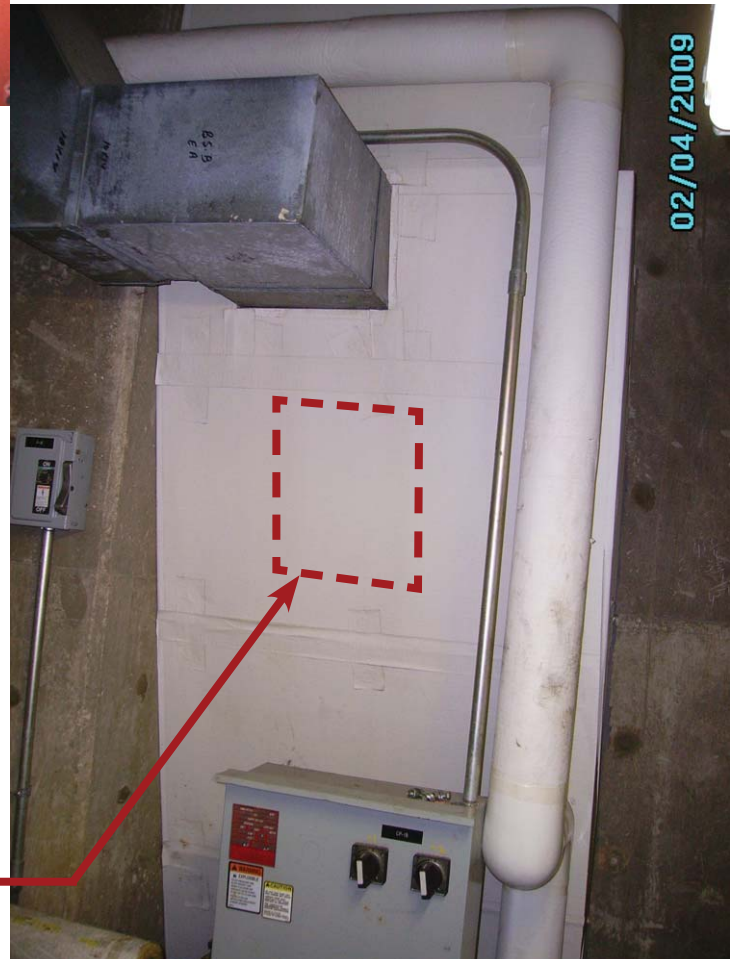

Photo 2: Existing plenum. New exhaust fan location. See sketch in Appx. B.



Photo 3: Gap under door to be filled.

Photo 4: Existing shroud at relief air louver



Photo 5: Exterior view of area well.

Appendix B

Plans and Details

New Work Plan	B 1
Damper Location Detail	B 2
Exhaust Fan Location	B 3
Proposed Relief Air Modifications	B 4

EX. SHEET-METAL BLANK-OFF
ON EX. LOUVER

DAMPER SUPPORTS

12" X 16" SLEEVE FOR
NEW OA DAMPER

EX. STEAM GENERATOR

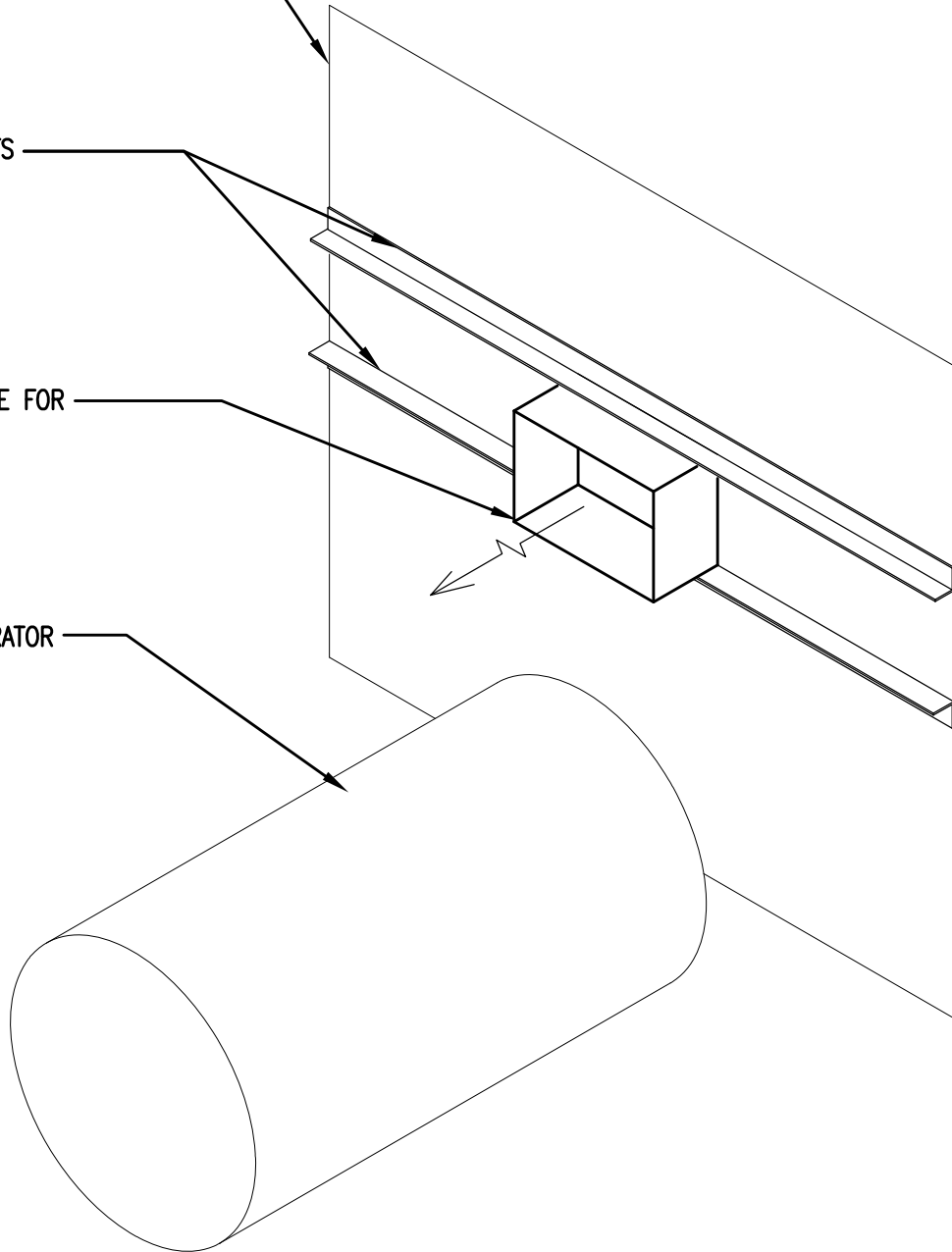

1

MAKE-UP AIR DAMPER LOCATION

NOT TO SCALE

Facilities & Services

ENGINEERING DEPARTMENT / ENGINEERING SERVICES

Physical Plant Service Building
1501 S. Oak St., Champaign, MC-800

General Information: 217.333.0697



HVAC EVALUATION

ILLINI UNION BOOKSTORE

BUILDING NO. 0106

Reviewed:	Drawn:
Proj. No.	- FEB 8, 2010
	Date:
2/28/10	PRELIMINARY
1/12/10	PRELIMINARY
# Date	Revision Description
	PRELIMINARY

DAMPER
LOCATION
DETAIL

B-2

of 4 sheets

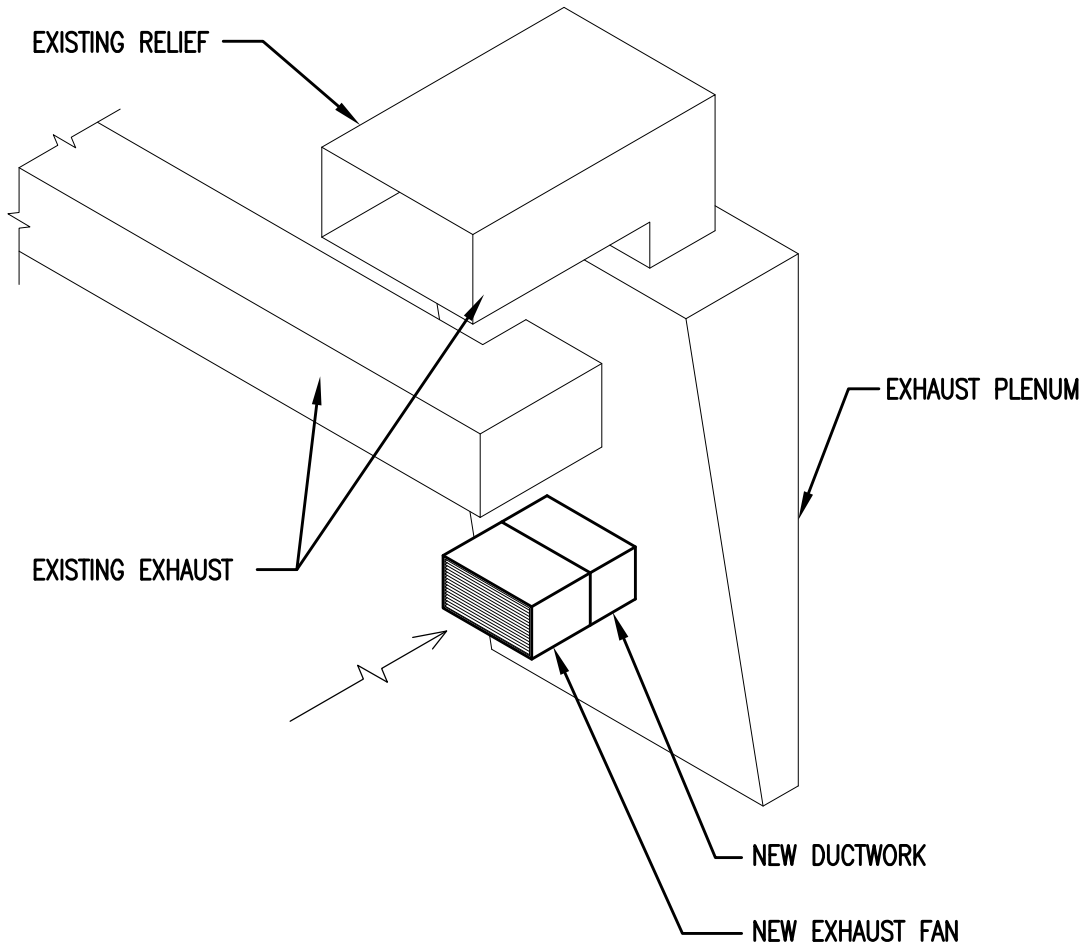

1

EXHAUST FAN LOCATION

NOT TO SCALE

Facilities & Services

ENGINEERING DEPARTMENT / ENGINEERING SERVICES

Physical Plant Service Building
1501 S. Oak St., Champaign, MC-800

General Information: 217.333.0697



HVAC EVALUATION

ILLINI UNION BOOKSTORE

BUILDING NO. 0106

Reviewed:	Drawn:
Proj. No.:	- FEB 8, 2010
	Date:
2/28/10	PRELIMINARY
1/12/10	PRELIMINARY
#	Date Revision Description
PRELIMINARY	

EXHAUST FAN LOCATION

B-3

of 4 sheets

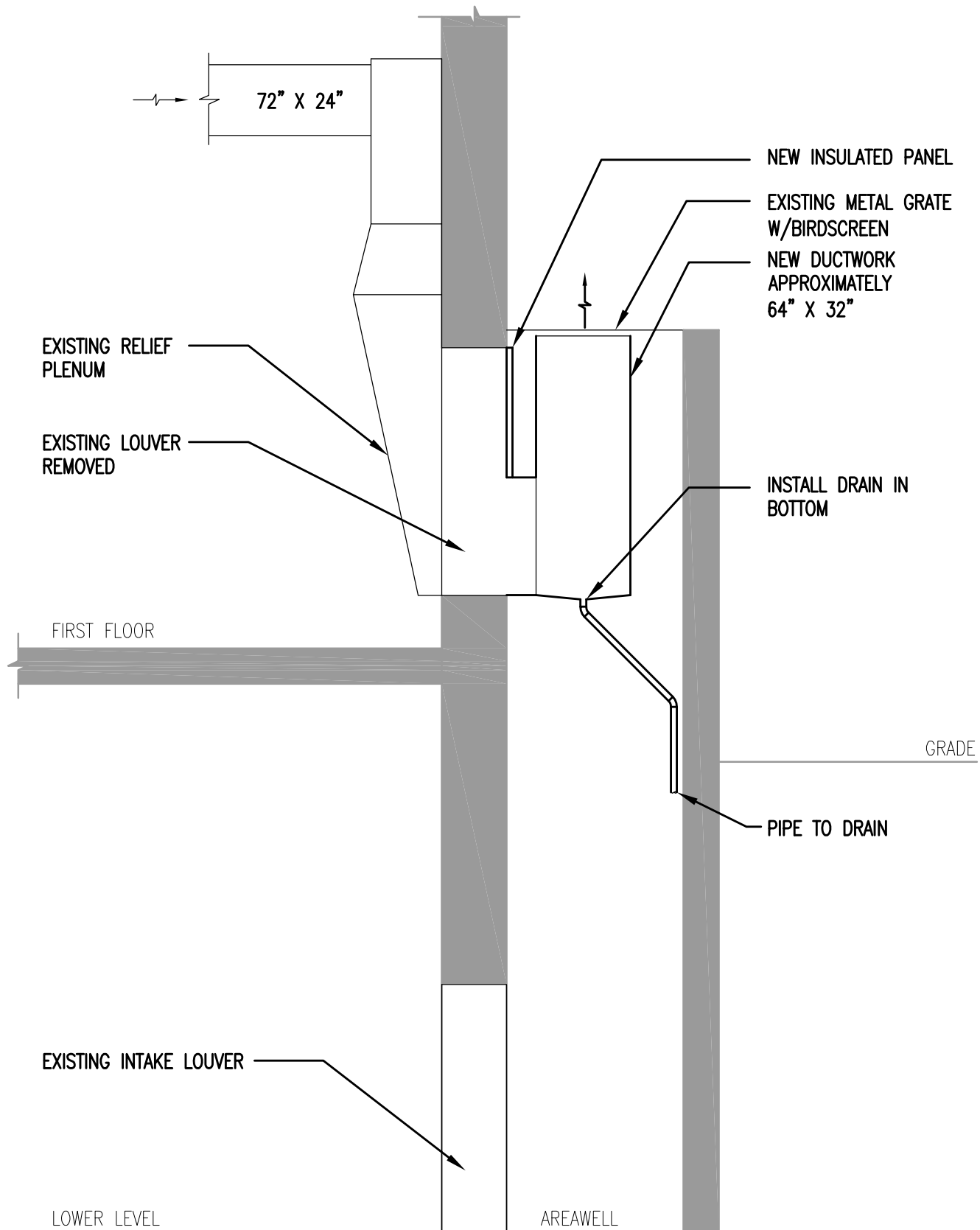

PROPOSED RELIEF AIR MODIFICATIONS

1

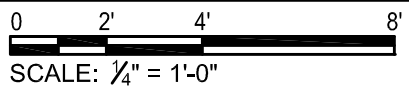

Facilities & Services ENGINEERING DEPARTMENT / ENGINEERING SERVICES Physical Plant Service Building 1501 S. Oak St., Champaign, MC-800 General Information: 217.333.0697		HVAC EVALUATION ILLINI UNION BOOKSTORE BUILDING NO. 0106	Reviewed: _____ Date: _____ Drawn: _____ Date: FEB 8, 2010	PROPOSED RELIEF AIR MODIFICATIONS						
		<table border="1" style="width: 100%; border-collapse: collapse;"> <thead> <tr> <th style="width: 5%;">#</th> <th style="width: 10%;">Date</th> <th style="width: 85%;">Revision Description</th> </tr> </thead> <tbody> <tr> <td>1</td> <td>1/20/10</td> <td>PRELIMINARY</td> </tr> <tr> <td>2</td> <td>2/8/10</td> <td>PRELIMINARY</td> </tr> </tbody> </table>	#	Date	Revision Description	1	1/20/10	PRELIMINARY	2	2/8/10
#	Date	Revision Description								
1	1/20/10	PRELIMINARY								
2	2/8/10	PRELIMINARY								

Appendix C

Product Data

Fan Product Data
Ruskin Damper Product Data

C 1
C 2 a-d

Fan

MARK: Mark 1

CSP

Inline Cabinet Fan

Tag: Mark 1

STANDARD CONSTRUCTION FEATURES

- Galvanized steel housing
- Sound absorbing insulation
- Outlet duct collar with integral spring loaded backdraft damper
- Forward curved wheel
- Plug type disconnect
- Adjustable mounting brackets
- Square duct connection
- Dual galvanized steel scroll design
- Field rotatable discharge

SELECTED OPTIONS & ACCESSORIES

- Motor w/ Thermal Overloads
- Solid State Speed Control - 5WSSC, Shipped Loose
- UL/cUL-507 - "Electric Fans"

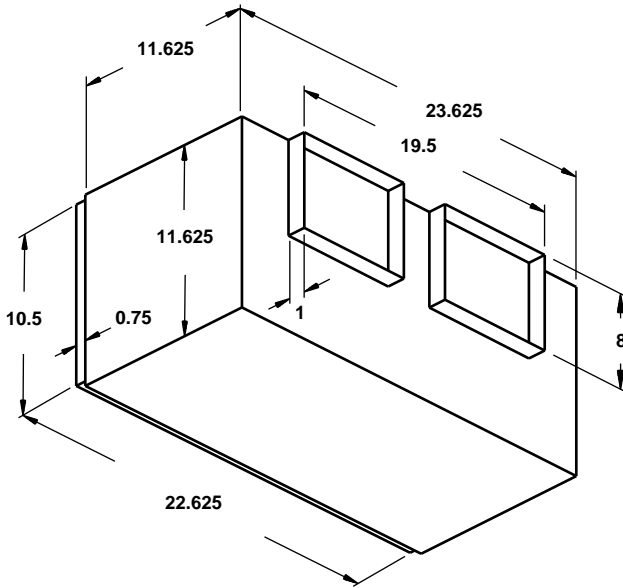

NOTES: All dimensions shown are in units of inches
Fan weight is without accessories

DIMENSIONS

Approx. Fan Weight (lb)
34

PERFORMANCE (Elevation ft = 777, Airstream Temperature F = 90)

Qty	Model	Volume (CFM)	SP (in wg)	FRPM	Watts (W)	Motor Information		
						V/C/P	Encl:	RPM
1	CSP-A700	250	0.4	702	350	115/60/1	ODP	1100

SOUND

Inlet Sound Power by Octave Band								Lwa	dBA	Sones
62.5	125	250	500	1000	2000	4000	8000			
56	48	35	31	30	30	28	25	38	27	0.6

FLA - Based on tables 150 or 148 of National Electrical Code 2002.

LwA - A weighted sound power level, based on ANSI S1.4.
dBA - A weighted sound pressure level, based on 11.5 dB attenuation per octave band at 5.0 ft. Sones calculated using AMCA 301 at 5.0 ft.

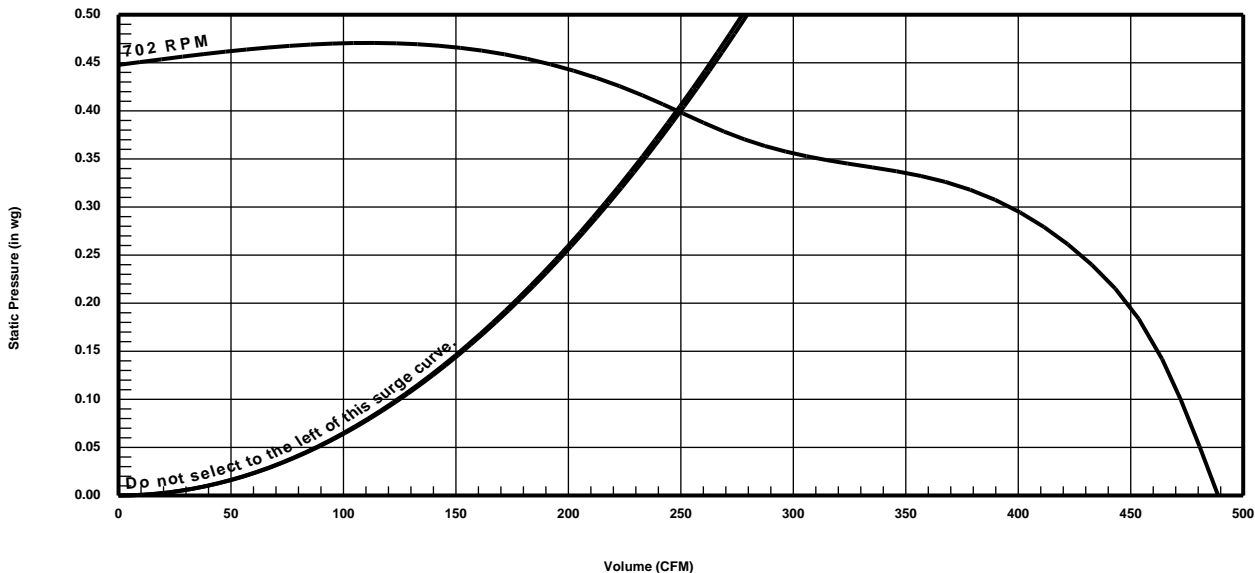

CD30AF1 and **CD30AF2** HEAVY DUTY AIRFOIL CONTROL DAMPERS

STANDARD CONSTRUCTION

FRAME

3" x 1" x 12 gage (76 x 25 x 2.8) galvanized steel U-channel.

BLADES

16 (1.6) gage galvanized steel airfoil shaped, double skin, 8" (203) maximum width.

AXLES

CD30AF1 - 1/2" (13) diameter plated steel.
CD30AF2 - 3/4" (19) diameter plated steel.

BEARINGS

Stainless steel pressed into frame.

LINKAGE

Face linkage in airstream.

FINISH

Mill galvanized.

MAXIMUM TEMPERATURE

250°F (121°C) is standard. Damper can be supplied for temperatures between 250°F (121°C) and 400°F (204°C) by increasing clearance between blade ends and frame. Advise Ruskin of maximum operating temperature.

MINIMUM SIZE

Single blade, parallel action - 5"w x 5"h (127 x 127).
Two blade, parallel or opposed action - 8"w x 14"h (203 x 356).

MAXIMUM SIZE

CD30AF1 single section - 48"w x 96"h (1219 x 2438).
CD30AF2 single section - 60"w x 96"h (1524 x 2438).
Multiple section assembly - Unlimited size.

Dimensions in parenthesis () indicate millimeters.

*Unit furnished approx. 1/4" (6) smaller than given "opening" dimensions.

VARIATIONS

Additional variations to those listed in table are available. Contact Ruskin for pricing.

- Heavier/Higher Temperature Construction.
- Special Finishes.

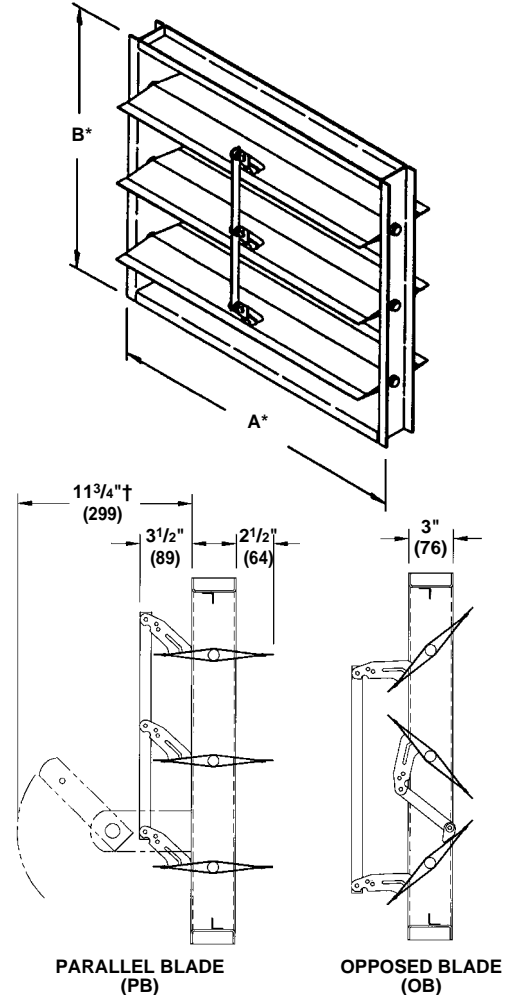

†Jackshaft used only on multiple section dampers.

FRAME		BLADES		SEALS (Opt)		AXLES		ACCESSORIES (Opt.)	
3" x 1" x 12 (76 x 25 x 2.8) gage galvanized U-Channel		16 (1.6) gage galvanized		EPDM Blade Seals 250°F (121°C)		Plated Steel		Hand Quadrant (HQ)	
3" x 1" x 14 (76 x 25 x 2) gage galvanized Hat Channel (Opt.)		14 (2) gage galvanized (Opt.)		Silicone Blade Seals 400°F (204°C)		304SS (Opt.)		Pneumatic Actuator	
3" x 1" x 12 (76 x 25 x 2.8) gage 304SS U-Channel (Opt.)		16 (1.6) gage 304SS (Opt.)		SS Jamb Seals		Aluminum (Opt.)		Electric Actuator	
3" x 1" x .125 (76 x 25 x 3.2) thick aluminum U-Channel (Opt.)		.080 (2) thick aluminum (Opt.)				Full Length (Opt.)			
						Bolted to Blades (Opt.)			

QTY.	MODEL	DIMENSIONS		BLADE ACTION		COMMENTS	TAG
		A	B	PB	OB		
JOB		LOCATION:					
CONTRACTOR							

CD30AF1 and CD30AF2 PERFORMANCE DATA

CD30AF PRESSURE LIMITATIONS

MODEL CD30AF1

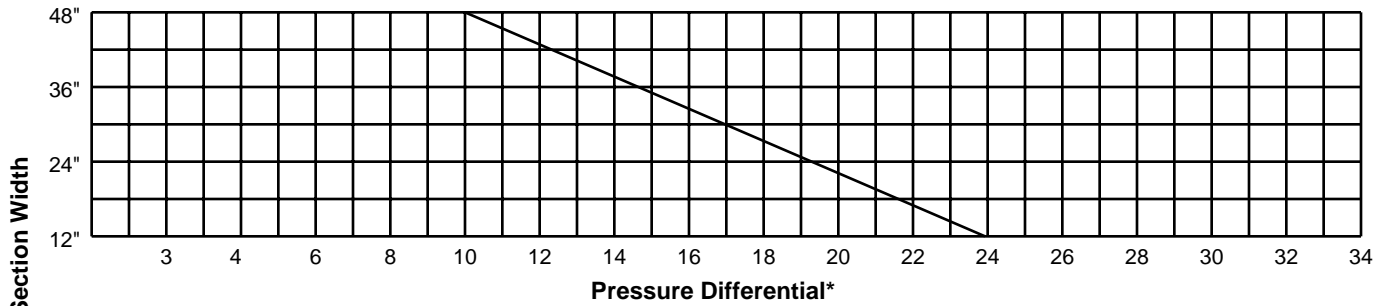

MODEL CD30AF2

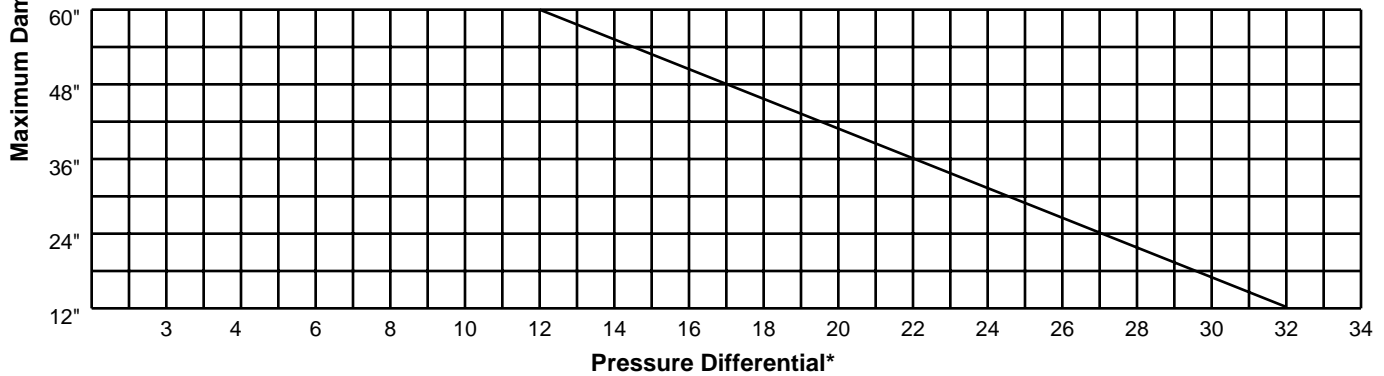

The CD30AF1 may be used in systems with total pressure exceeding 10" w.g. by reducing the damper section width as indicated above. For example, maximum design total pressure of 17" w.g. would require a CD30AF1 damper with maximum section width of 30".

The CD30AF2 may be used in systems with total pressure exceeding 12" w.g. by reducing the damper section width as indicated in the chart. A maximum design total pressure of 27" w.g., for example, would require a CD30AF2 damper with maximum section width of 24".

***NOTE:** Damper should be specified for fan shut off pressure. Pressure differential is **not** system pressure but is the maximum pressure the damper will encounter with blades closed.

CD30AF1 PERFORMANCE DATA								
Damper Width Inches (MM)	Maximum System Pressure	Maximum System Velocity	Leakage without Seals*		Leakage with Seals*		Ultra-Low Leakage**	
			Percent of max. flow	CFM/sq. ft.	Percent of max. flow	CFM/sq. ft.	Percent of max. flow	CFM/sq. ft.
48" (1219)	10.0" w.g.	4000 fpm	0.80	32.0	0.10	4.0	0.07	2.9
36" (914)	14.8" w.g.	4000 fpm	0.80	32.0	0.10	4.0	0.07	2.9
24" (610)	19.3" w.g.	4000 fpm	0.80	40.0	0.20	8.0	0.15	5.8
12" (305)	24.0" w.g.	4000 fpm	1.00	60.0	0.33	13.0	0.24	9.5

CD30AF2 PERFORMANCE DATA								
Damper Width Inches (MM)	Maximum System Pressure	Maximum System Velocity	Leakage without Seals*		Leakage with Seals*		Ultra-Low Leakage**	
			Percent of max. flow	CFM/sq. ft.	Percent of max. flow	CFM/sq. ft.	Percent of max. flow	CFM/sq. ft.
60" (1524)	12.0" w.g.	4000 fpm	0.80	32.0	0.10	4.0	0.07	2.9
48" (1219)	17.0" w.g.	4000 fpm	0.80	32.0	0.10	4.0	0.07	2.9
36" (914)	22.0" w.g.	4000 fpm	0.80	32.0	0.10	4.0	0.07	2.9
24" (610)	27.0" w.g.	5000 fpm	0.80	40.0	0.16	8.0	0.12	5.8
12" (305)	32.0" w.g.	6000 fpm	1.00	60.0	0.22	13.0	0.19	9.5

Dampers may tolerate higher pressures and velocities than those listed here. Conservative ratings are presented intentionally in an effort to avoid misapplication. Consult Ruskin or your Ruskin representative when a damper is to be applied in conditions exceeding recommended maximums.

*Leakage information based on pressure differential of 1" w.g. tested per AMCA Std. 500.

**For details on "Ultra-Low Leakage," contact Ruskin.

PRESSURE DROP

AREA FACTOR TABLE

Height Dim. B	Dimension A – Width In Inches											
	8" (203)	12" (305)	16" (406)	20" (508)	24" (610)	28" (711)	30" (762)	32" (813)	36" (914)	40" (1016)	44" (1118)	48" (1219)
9" (229)	4.57	2.75	1.96	1.52	1.25	1.06	.979	.968	.957	.903	.813	.738
10" (254)	3.84	2.28	1.62	1.27	1.04	.880	.813	.877	.774	.731	.657	.598
12" (305)	3.19	1.94	1.39	1.08	.880	.744	.690	.708	.625	.590	.531	.482
14" (356)	2.52	1.52	1.08	.842	.690	.564	.542	.542	.498	.440	.406	.369
16" (406)	2.08	1.25	.889	.690	.564	.477	.444	.438	.386	.365	.329	.299
20" (508)	1.62	.969	.696	.542	.443	.374	.347	.335	.295	.279	.251	.228
24" (610)	1.32	.799	.571	.444	.364	.309	.287	.271	.239	.225	.203	.185
28" (711)	1.08	.649	.464	.361	.296	.249	.232	.219	.193	.182	.164	.149
32" (813)	.950	.568	.406	.316	.259	.218	.202	.190	.168	.158	.142	.129
36" (914)	.842	.505	.361	.280	.229	.193	.180	.168	.147	.139	.125	.114
40" (1016)	.732	.439	.313	.244	.199	.168	.156	.145	.128	.121	.109	.099
44" (1118)	.663	.397	.284	.221	.180	.152	.142	.132	.117	.126	.098	.090
48" (1219)	.607	.364	.260	.203	.165	.140	.129	.120	.106	.100	.091	.082
54" (1372)	.502	.285	.209	.165	.144	.117	.108	.101	.091	.080	.073	.067
60" (1524)	.448	.255	.187	.148	.129	.104	.096	.090	.080	.072	.065	.059
66" (1676)	.406	.230	.170	.133	.116	.094	.087	.082	.072	.065	.059	.053
72" (1829)	.371	.211	.156	.122	.102	.086	.080	.075	.066	.059	.053	.048
78" (1981)	.365	.205	.152	.115	.100	.080	.075	.070	.062	.055	.050	.045
84" (2134)	.361	.200	.149	.110	.093	.078	.073	.068	.060	.052	.050	.043
90" (2286)	.333	.196	.138	.104	.087	.073	.068	.061	.056	.051	.046	.041
96" (2438)	.290	.181	.128	.097	.080	.070	.063	.058	.052	.050	.042	.039

DETERMINING PRESSURE DROP

Use the Area Factor Table and Pressure Drop Chart to determine pressure drop through Ruskin CD30AF1/CD30AF2 control dampers.

1. Determine area factor for damper by entering the Area Factor Table through duct width and height.
2. Find the conversion velocity (CV) by multiplying the selected size damper's area factor by the flow rate in CFM: **CV = Area Factor x CFM**.
3. Enter the Pressure Drop Chart at the determined area factor and proceed up to appropriate conversion velocity (CV) line. Then, read across to static pressure drop at left side of chart.

CD30AF PRESSURE DROP CHART

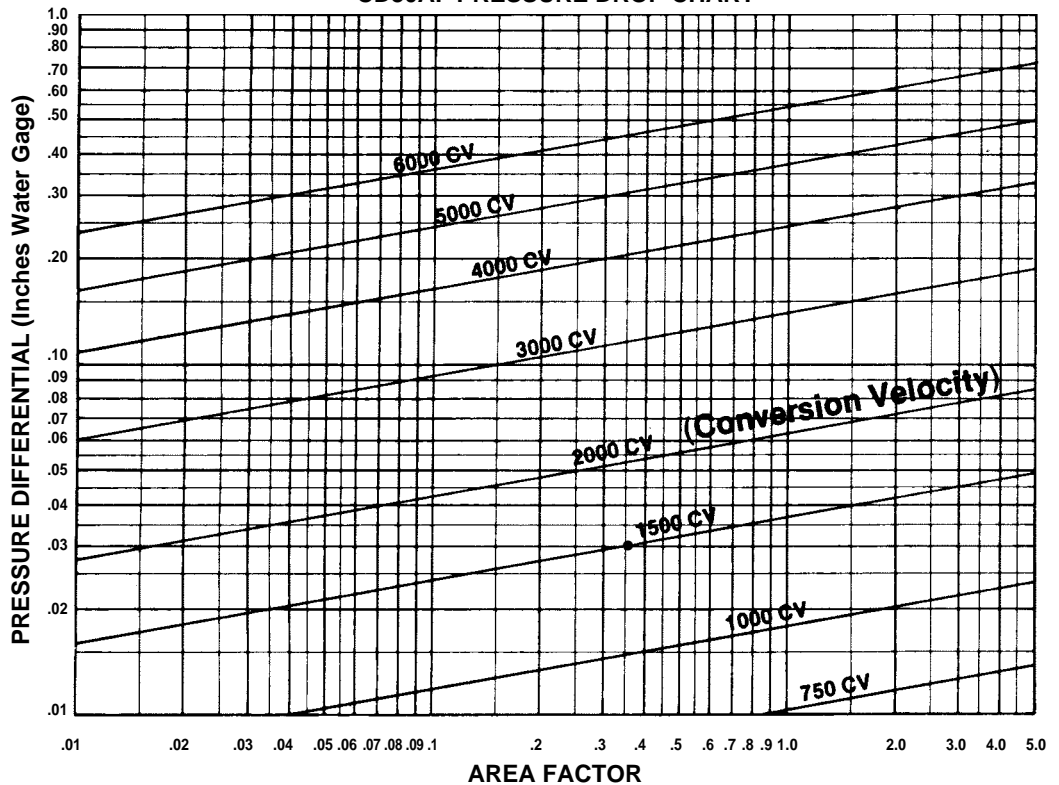

Example:

Find the pressure drop across a 36" wide x 36" high Model CD30AF2 control damper handling 20408 CFM. From the Area Factor Table, the area factor is determined to be .147.

**CFM x AREA FACTOR
EQUALS CONVERSION
VELOCITY**

Therefore, CV (Conversion Velocity) = 20408 CFM x .147 = 3000. Using the Pressure Drop Chart, pressure drop = .098 inches water gage.

NOTE:

1. Ratings are based on AMCA Standard 500 using Test Setup Apparatus Figure 5.3 (damper is installed with duct upstream and downstream).
2. Static Pressure and Conversion Velocities are corrected to .075 lb./cu. ft. air density.

CD30 SERIES SUGGESTED SPECIFICATION

Furnish and install, at locations shown on plans or in accordance with schedules, industrial grade induct mount control dampers meeting the following minimum construction standards. Damper frame shall be 3" deep x 1" x 12 gage (76 x 25 x 2.8) galvanized steel. Blades shall be formed double skin airfoil shaped construction, maximum 8" (203) wide and minimum 16 (1.6) gage galvanized steel. Axle material shall be plated steel rod (specifier select based on model) 1/2" (13) (or) 3/4" (19) diameter. Bearings shall be stainless steel sleeve pressed into frame. Oil impregnated bronze, synthetic, or bolt on style are not acceptable. Linkage shall be located on damper blade face in airstream for easy access and maintenance. External linkage out of airstream is not acceptable. Maximum pressure drop across a 48" x 48" (1219 x 1219) unit shall not exceed .06" w.g. at 32,000 CFM. Standard damper design shall allow application in system with (specifier select based on model)

10" (or) 17" SP across a minimum 48" (1219) long blade. Submittal data must include published leakage, pressure drop, and maximum pressure data based on AMCA Standard 500 testing. Data shall be for a full range of damper sizes. Data from one size sample is not acceptable. Damper shall be Ruskin model (specifier select) CD30AF1 (or) CD30AF2.

ADD TO SPECIFICATION IF REQUIRED:

Dampers shall be equipped with blade and jamb seals for low leakage application. Blade seals shall be mechanically attached to the blade. Adhesive type seals are not acceptable. Jamb seals shall be flexible stainless steel located between the blade edge and jamb for maximum sealing compression. Windstops or sponge seals are not acceptable. Leakage shall not exceed 4 CFM per square foot at 1" SP.

INSTALLATION

For proper operation, damper must be installed square and free from racking. Opposed blade dampers must be operated from a power blade or drive axle.

Dampers are self supporting only in largest single section size. Multiple section assemblies require bracing to support assembly weight and to hold against system pressure. Ruskin recommends appropriate bracing at every horizontal and vertical mullion.

NOTE: Dampers are designed for operation with blades running horizontally. Dampers are not recommended for installation with blades running vertically.



3900 Dr. Greaves Rd.
Kansas City, MO 64030
(816) 761-7476
FAX (816) 765-8955