



STUDENT SUSTAINABILITY COMMITTEE

Scope Change

From time-to-time unforeseen challenges or opportunities can affect the planned budget, timeline, or overall goals of a project funded by the Student Sustainability Committee. Past examples of these situations include projects coming in under budget but having additional opportunities available, or inclement weather delaying the planting of agriculture projects.

Below please include a brief project summary and your requested changes. Attach additional documents as needed. If you have any questions, please contact the Student Sustainability Committee at sustainability-committee@illinois.edu.

General Information

Project Name: InSPIRE Solar Charging Station

Total Amount Requested from SSC: \$5800

Contact Information

Applicant Name: Justin Habana

Unit/Department: Institute for Scientific Progress, Innovation, Research and Edu-training
(InSPIRE) RSO

Email Address: jhabana2@illinois.edu

Project Information

Please provide a brief background of the project, the goals, and the desired outcomes:

The SPOT project is a completely student designed and implemented outdoors table which will be retrofitted with solar panels used to charge an off grid solar energy system. The plan is to provide students in UIUC a space to sit and study outside while charging their devices (cellphones, tablets, laptops etc.) using solar energy. It will also better promote solar energy by allowing students to interact with solar energy first-hand through solar panels they can clearly see in-front of them. Lastly, the current plan is to provide a QR code on the SPOT which will direct students and RSOs to a website detailing design and construction plans for the project. This will allow students and other RSOs to replicate the project or parts of it in their own endeavors. The website will also include instructions to create an off-grid solar energy system.

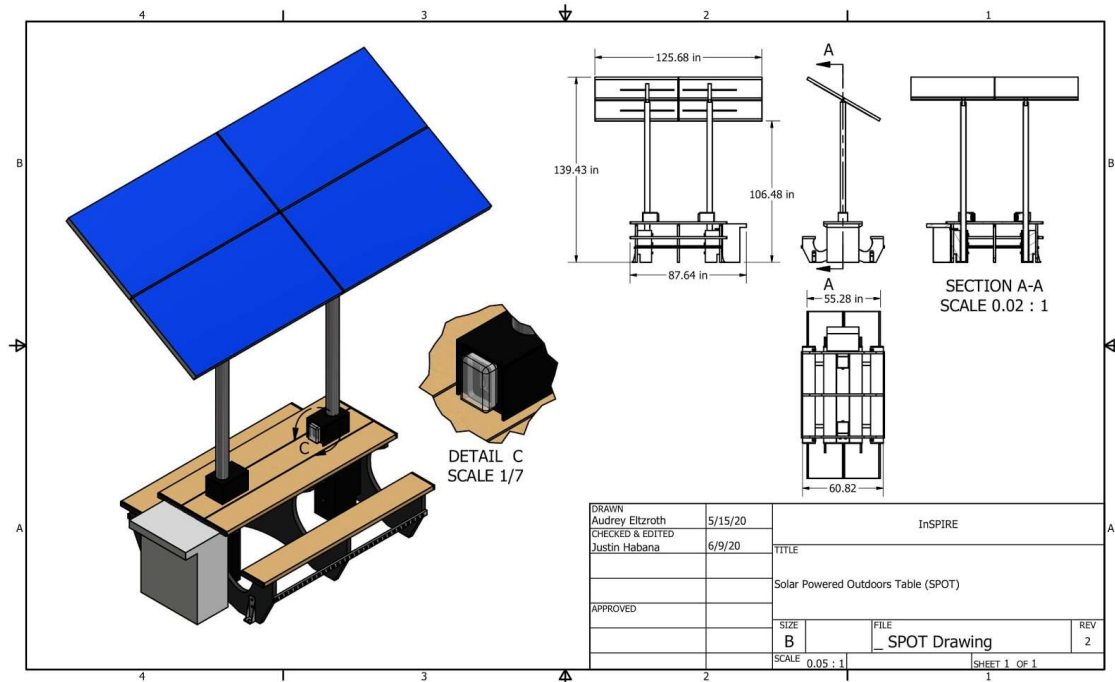

Please provide a brief summary of how students will be involved in the project's changes:

Students will be responsible for the following.

- Overall design of the table including what major components will be commercially bought and what will be created from scratch.
- Cooperating with professionals for consultation on the design, construction and compliance with local campus codes as well as statewide & national codes.
- Construction
- Marketing
- Creation of signs
- Creation of the website with the design documents available to the public

Please provide a brief summary of your requested scope change. How is your request different from your original plan?

The project was estimated to be completed in May 2020. Due to the COVID pandemic, we could not meet in person and communications were very slow. This would also mean we could not start the construction. The completion of the project has been delayed to May 2021.

Additional comments (Optional)

We previously thought a scope change was already submitted in May 2020, before the SSC deadline to finish the project. In case the previous scope change request was not actually sent or was not received, this is being sent. To clarify, the only change to the scope is the estimated time of completion which was previously May 2020 to May 2021.